

HS1L Interlock Switches with Solenoid

3000N locking strength (strongest* in class)!

Suitable for large and heavy doors.

Same actuators as HS1E (locking strength 3000N) can be used.

Six contacts in a compact housing (same size as HS1E)!

Same dimensions and mounting hole layouts as HS1E.

Size: 35 × 104 × 129mm

Door open, closed, and locked status can be monitored for various applications.



New energy saving design!

Energy efficient new solenoid unit.

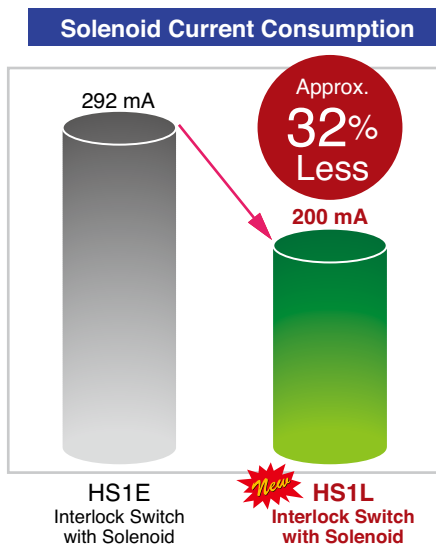

Improved safety and usability!

- Manual unlock key and LED indicator are standard.
- Manual unlock key allows for manual unlocking in the event of power failure or maintenance.
- Indicator has an independent circuit, and can be used for various applications.
- Two locking mechanisms to choose from—spring lock (unlocked with energized solenoid) or solenoid lock (locked with energized solenoid).
- M3 terminal screws for wiring.
- Wide operating temperature range (−20 to +55°C).

*As of October 2009, according to IDEC research of plastic interlock switches with solenoid.

HS1L Interlock Switches with Solenoid

Specifications

Applicable Standard	ISO14119
	IEC60947-5-1
	EN60947-5-1 (TÜV approval)
	GS-ET-19 (TÜV approval)
	UL508 (UL listed) CSA C22.2 No. 14 (c-UL listed)
	IEC60204-1/EN60204-1 (applicable standards for use)
Operating Temperature	-20 to +55°C (no freezing)
Relative Humidity	45 to 85% (no condensation)
Storage Temperature	-40 to +80°C (no freezing)
Pollution Degree	3
Overtoltage Category	III
Impulse Withstand Voltage	4.0kV (between LED, solenoid and ground: 1.5 kV)
Contact Resistance	50mΩ maximum (initial value)
Insulation Resistance	Between live and dead metal parts: 100MΩ minimum (500V DC megger) Between terminals of different poles: 100MΩ minimum (500V DC megger)
Electric Shock Protection	Class II (IEC 61140)
Degree of Protection	IP67 (IEC 60529)
Shock Resistance	Damage limits: 1000m/s ²
Vibration Resistance	Operating extremes: 10 to 55Hz, amplitude 0.35mm Damage limits: 30Hz, amplitude 1.5mm
Actuator Operating Speed	0.05 to 1.0 m/s
Direct Opening Travel	11mm minimum
Direct Opening Force	50N minimum
Actuator Retention Force when Locked	3000N minimum (GS-ET-19)
Operating Frequency	900 operations per hour
Mechanical Durability	1,000,000 operations minimum (GS-ET-19)
Electrical Durability	100,000 operations minimum (AC-15 3A/250V) 1,000,000 operations minimum (24V AC/DC, 100mA) (operating frequency 900 operations per hour)
Conditional Short-circuit Current	100A (250V) (Use 250V/10A fast acting type fuse for short-circuit protection.)
Weight (approx.)	450g (HS1L-DQ44)

Part Number Guide

HS1L-DQ44KMSRP-R

Circuit Code	LED Color
Main Circuit	G: Green
Monitor Circuit	R: Red
R: 1NC+1NC	Conduit Port Size
1NC/1NO, 2NC	Blank: 1/2
DQ: 1NC+1NC/ 1NC+1NC	P: PG13.5
DT: 1NC+1NC/ 1NC+1NC	M: M20
	Housing Color
	R: Red and Black
Solenoid Unit Voltage/ Lock Mechanism	Locking Strength
4: 24V DC/Spring Lock	MS: 3000N
7Y: 24V DC/Solenoid Lock	Manual Unlocking Key
LED Rated Voltage	K: With key
4: 24V DC	

• Actuator

Description	Part Numbers
Straight Actuator	HS9Z-A1S
L-shaped Actuator	HS9Z-A2S
Angle Adjustable (vertical) Actuator (for hinged door)	HS9Z-A3S

• Package quantity: 1

Ratings

• Contact Ratings

Rated Insulation Voltage (Ui)		300V			
Rated Operating Current (Ith)		10A			
Rated Operating Voltage (Ue)		30V	125V	250V	
Rated Operating Current (Ie)	AC	Resistive Load (AC-12)	10A	10A	6A
		Inductive Load (AC-15)	10A	5A	3A
	DC	Resistive Load (DC-12)	8A	2.2A	1.1A
		Inductive Load (DC-13)	4A	1.1A	0.6A

• Minimum applicable load (reference value): 3V AC/DC, 5mA
(Applicable range may vary with operating conditions and load types.)

• TÜV rating: AC-15 3A/250V, DC-13 4A/30V
UL, c-UL rating: A300
Pilot duty: AC 3A/250V
Pilot duty: DC 4A/30V

• Solenoid Unit and LED Indicator

Lock Mechanism	Spring Lock	Solenoid Lock
Solenoid	Rated Operating Voltage	24V DC (100% duty cycle)
	Rated Current	200 mA (initial value)
	Coil Resistance	120Ω (at 20°C)
	Pickup Voltage	Rated voltage × 85% max. (at 20°C)
	Dropout Voltage	Rated voltage × 10% max. (at 20°C)
	Maximum Continuous Applicable Voltage	Rated voltage × 110%
	Maximum Continuous Applicable Time	Continuous
	Insulation Class	Class F
LED	Rated Operating Voltage	24V DC
	Rated Current	10 mA
	Light Source	LED
	Illumination Color	Green (G), Red (R)

Parts and Functions

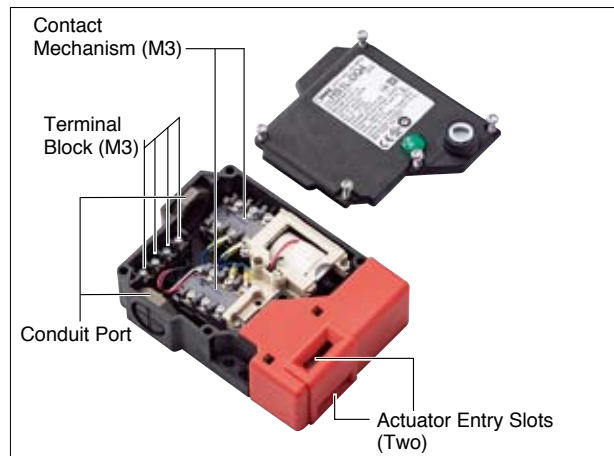

• Accessories

Description	Part Numbers
Key Wrench for TORX Screw (L-shaped)	HS9Z-T1
Conduit Port Plug (Size: G1/2 only)	HS9Z-P1

• Package quantity: 1
• Key Wrench for TORX Screw is supplied with the interlock switch.

HS1L Interlock Switches with Solenoid

Types

Lock Mechanism	Circuit Code	Contact Configuration	Manual Unlocking Key	Conduit Port Size	LED Indicator	Part Number
Spring Lock	R	<p>Main: 1NC+1NC Door monitor: 1NO/1NC Lock monitor: 2NC</p> <p>Main circuit: 11 12 41 42 Monitor circuit: 21 22 Monitor circuit: 33 34 Monitor circuit: 51 52 Monitor circuit: 61 62</p>	With	G1/2	Red	HS1L-R44KMSR-R
					Green	HS1L-R44KMSR-G
				PG13.5	Red	HS1L-R44KMSRP-R
					Green	HS1L-R44KMSRP-G
				M20	Red	HS1L-R44KMSRM-R
					Green	HS1L-R44KMSRM-G
	DQ	<p>Main: 1NC+1NC 1NC+1NC Door monitor: 1NO Lock monitor: 1NO</p> <p>Main circuit: 11 12 41 42 Main circuit: 21 22 51 52 Monitor circuit: 33 34 Monitor circuit: 63 64</p>		G1/2	Red	HS1L-DQ44KMSR-R
					Green	HS1L-DQ44KMSR-G
				PG13.5	Red	HS1L-DQ44KMSRP-R
					Green	HS1L-DQ44KMSRP-G
				M20	Red	HS1L-DQ44KMSRM-R
					Green	HS1L-DQ44KMSRM-G
DT	<p>Main: 1NC+1NC 1NC+1NC Door monitor: 1NC Lock monitor: 1NC</p> <p>Main circuit: 11 12 41 42 Main circuit: 21 22 51 52 Monitor circuit: 31 32 Monitor circuit: 61 62</p>	G1/2	Red	HS1L-DT44KMSR-R		
			Green	HS1L-DT44KMSR-G		
		PG13.5	Red	HS1L-DT44KMSRP-R		
			Green	HS1L-DT44KMSRP-G		
		M20	Red	HS1L-DT44KMSRM-R		
			Green	HS1L-DT44KMSRM-G		
Solenoid Lock	R	<p>Main: 1NC+1NC Door monitor: 1NO/1NC Lock monitor: 2NC</p> <p>Main circuit: 11 12 41 42 Monitor circuit: 21 22 Monitor circuit: 33 34 Monitor circuit: 51 52 Monitor circuit: 61 62</p>	With	G1/2	Red	HS1L-R7Y4KMSR-R
					Green	HS1L-R7Y4KMSR-G
				PG13.5	Red	HS1L-R7Y4KMSRP-R
					Green	HS1L-R7Y4KMSRP-G
				M20	Red	HS1L-R7Y4KMSRM-R
					Green	HS1L-R7Y4KMSRM-G
	DQ	<p>Main: 1NC+1NC 1NC+1NC Door monitor: 1NO Lock monitor: 1NO</p> <p>Main circuit: 11 12 41 42 Main circuit: 21 22 51 52 Monitor circuit: 33 34 Monitor circuit: 63 64</p>		G1/2	Red	HS1L-DQ7Y4KMSR-R
					Green	HS1L-DQ7Y4KMSR-G
				PG13.5	Red	HS1L-DQ7Y4KMSRP-R
					Green	HS1L-DQ7Y4KMSRP-G
				M20	Red	HS1L-DQ7Y4KMSRM-R
					Green	HS1L-DQ7Y4KMSRM-G
DT	<p>Main: 1NC+1NC 1NC+1NC Door monitor: 1NC Lock monitor: 1NC</p> <p>Main circuit: 11 12 41 42 Main circuit: 21 22 51 52 Monitor circuit: 31 32 Monitor circuit: 61 62</p>	G1/2	Red	HS1L-DT7Y4KMSR-R		
			Green	HS1L-DT7Y4KMSR-G		
		PG13.5	Red	HS1L-DT7Y4KMSRP-R		
			Green	HS1L-DT7Y4KMSRP-G		
		M20	Red	HS1L-DT7Y4KMSRM-R		
			Green	HS1L-DT7Y4KMSRM-G		

- The contact configuration shows the status when the actuator is inserted and the switch is locked.
- Actuators are not supplied with the interlock switch and must be ordered separately.

Terminal Numbers

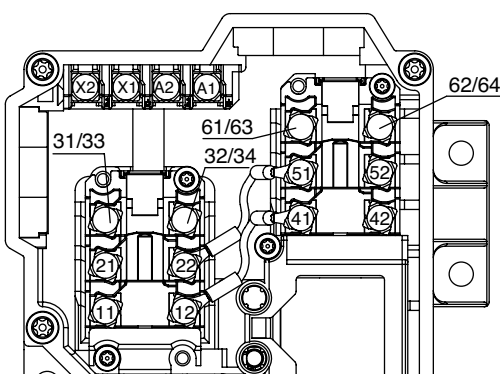

- 11-42: Main circuit
- 21: Main circuit or monitor circuit (door monitor)
- 22: Monitor circuit (door monitor)
- 31/33: Monitor circuit (door monitor)
- 32/34: Monitor circuit (door monitor)
- 51: Monitor circuit (lock monitor)
- 52: Main circuit or monitor circuit (lock monitor)
- 61/63: Monitor circuit (lock monitor)
- 62/64: Monitor circuit (lock monitor)
- A1: Solenoid (-)
- A2: Solenoid (+)
- X1: LED (-)
- X2: LED (+)

* There is no wiring between 22-51 with circuit code R.

HS1L Interlock Switches with Solenoid

Dimensions and Mounting Hole Layouts (mm)

• Interlock switch when using straight actuator (HS9Z-A1S)

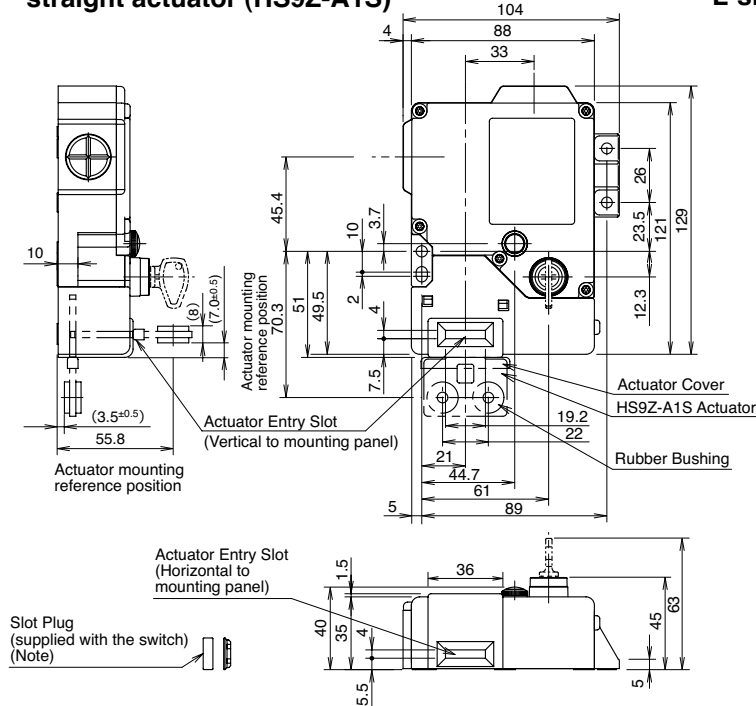

• Interlock switch when using L-shaped actuator (HS9Z-A2S)

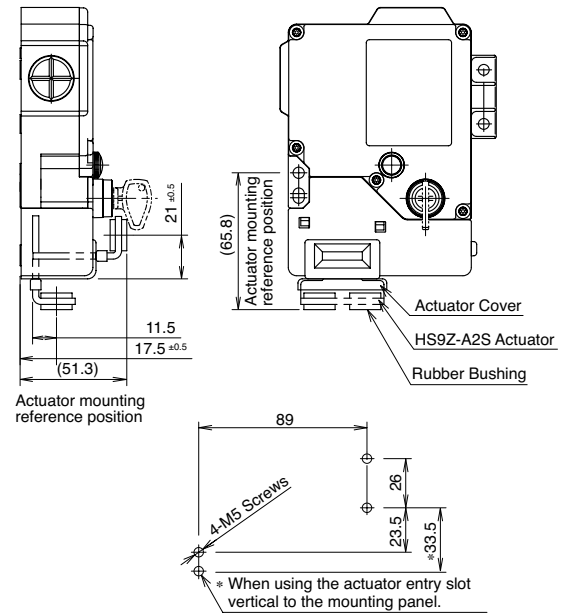

Interlock Switch Mounting Hole Layout

Note: Plug the unused actuator entry slot with the slot plug supplied with the interlock switch.

* Install the interlock switch using four mounting screws when using the actuator entry slot vertical to the mounting panel, and three mounting screws when using the actuator entry slot horizontal to the mounting panel.

• Straight Actuator (HS9Z-A1S)

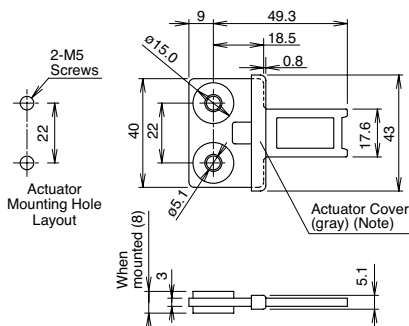

• L-shaped Actuator (HS9Z-A2S)

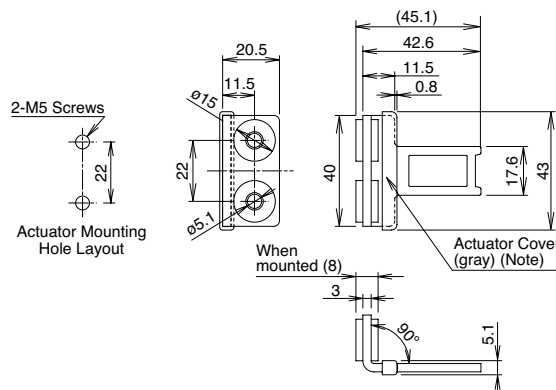

• Angle Adjustable (vertical) Actuator (HS9Z-A3S)

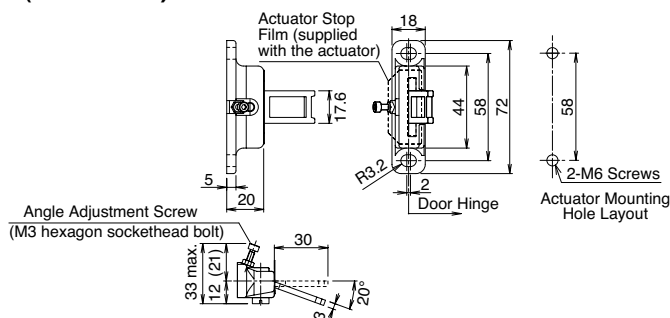

Note: The actuator cover and the actuator stop film are supplied with the actuator and used when adjusting the actuator position. Remove them after the actuator position has been determined.

• Actuator Mounting Reference Position

As shown in the figure on the right, the mounting reference position of the actuator, when inserted in the interlock switch, is where the actuator stop placed on the actuator lightly touches the interlock switch.

Note: After mounting the actuator, remove the actuator cover and stop film.

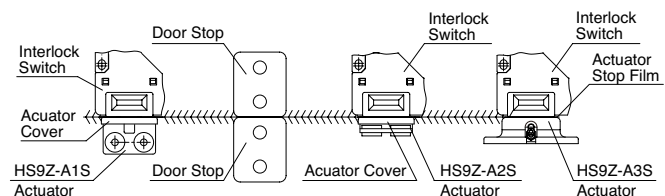

HS1L Interlock Switches with Solenoid

Circuit Diagrams and Operating Characteristics

• Spring Lock Type

		Status 1	Status 2	Status 3	Status 4	Manual Unlock	
Interlock Switch Status		<ul style="list-style-type: none"> Door Closed Machine ready to operate Solenoid de-energized 	<ul style="list-style-type: none"> Door Closed Machine cannot be operated Solenoid energized 	<ul style="list-style-type: none"> Door Open Machine cannot be operated Solenoid energized 	<ul style="list-style-type: none"> Door Open Machine cannot be operated Solenoid de-energized 	<ul style="list-style-type: none"> Door Closed Machine cannot be operated Solenoid de-energized 	
Door Status							
Circuit Diagram (HS1L-DQ4)							
Door		Closed (locked)	Closed (unlocked)	Open	Open	Closed (unlocked)	
Contact Configuration	HS1L-DQ4	Main Circuit 11-42	ON (closed)	OFF (open)	OFF (open)	OFF (open)	
		Main Circuit 21-52	ON (closed)	OFF (open)	OFF (open)	OFF (open)	
		Door Monitor Circuit (Door Open) 33-34	OFF (open)	OFF (open)	ON (closed)	ON (closed)	OFF (open)
		Lock Monitor Circuit (unlocked) 63-64	OFF (open)	ON (closed)	ON (closed)	ON (closed)	ON (closed)
Solenoid Power A1-A2		OFF (de-energized)	ON (energized)	ON (energized)	OFF (de-energized)	OFF (de-energized)	

• Solenoid Lock Type

		Status 1	Status 2	Status 3	Status 4	Manual Unlock	
Interlock Switch Status		<ul style="list-style-type: none"> Door Closed Machine ready to operate Solenoid energized 	<ul style="list-style-type: none"> Door Closed Machine cannot be operated Solenoid de-energized 	<ul style="list-style-type: none"> Door Open Machine cannot be operated Solenoid de-energized 	<ul style="list-style-type: none"> Door Open Machine cannot be operated Solenoid energized 	<ul style="list-style-type: none"> Door Closed Machine cannot be operated Solenoid de-energized to energized 	
Door Status							
Circuit Diagram (HS1L-DQ4)							
Door		Closed (locked)	Closed (unlocked)	Open	Open	Closed (unlocked)	
Contact Configuration	HS1L-DQ7Y	Main Circuit 11-42	ON (closed)	OFF (open)	OFF (open)	OFF (open)	
		Main Circuit 21-52	ON (closed)	OFF (open)	OFF (open)	OFF (open)	
		Door Monitor Circuit (Door Open) 33-34	OFF (open)	OFF (open)	ON (closed)	ON (closed)	OFF (open)
		Lock Monitor Circuit (unlocked) 63-64	OFF (open)	ON (closed)	ON (closed)	ON (closed)	ON (closed)
Solenoid Power A1-A2		ON (energized)	OFF (de-energized)	OFF (de-energized)	ON (energized) (Note 2)	OFF to ON (Note 1) (Note 2)	

Note 1: Do not attempt manual unlocking while the solenoid is energized.

Note 2: Do not energize the solenoid for a long period of time while the door is open or manually unlocked.

• Operation Characteristics (reference)

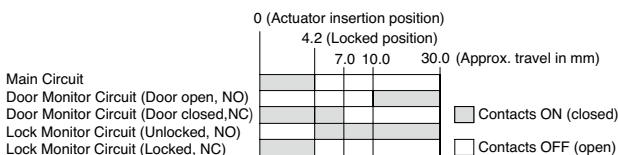

- The operation characteristics show the contact status when the actuator enters into the center of the entry slot.
- The circuit No. 12-41 and 22-51 are interconnected. Use circuits 11-42 and 21-52 for safety circuits (In HS1L-R type, circuit 12-41 is interconnected.)

HS1L Interlock Switches with Solenoid

Safety Precautions

- In order to avoid electric shock or fire, turn power off before installation, removal, wiring, maintenance, or inspection of the interlock switch.
- If relays are used in the circuit between the interlock switch and the load, consider the danger, and use safety relays, since welded or sticking contacts of standard relays may invalidate the functions of the interlock switch. Perform a risk assessment and establish a safety circuit which satisfies the requirement of the safety category.
- Do not place a PLC in the circuit between the interlock switch and the load. Safety security can be endangered in the event of a malfunction of the PLC.
- Do not disassemble or modify the interlock switch, otherwise the switch may fail or an accident may occur.
- Do not install the actuator in a location where someone may come in contact with it as injury may occur.
- Install the actuator where it does not touch anyone when the door is opened/closed as injury may occur.
- The solenoid lock type is locked when energized, and unlocked when de-energized. When energization is interrupted due to wire disconnection or other failures, the interlock switch may be unlocked causing possible danger to the operators. Solenoid lock type must not be used in applications where locking is required for safety. Perform a risk assessment and determine whether a solenoid lock type is appropriate.
- In order to prevent the interlock switch and actuator from being removed without authorization, it is recommended to install an one-way screw or a screw that needs a special tool for removal. Welding or rivets are also recommended.

Instructions

- Regardless of door types, do not use the interlock switch as a door stop. Install a mechanical door stop at the end of the door to protect the interlock switch from excessive force.
- Make sure that no force is applied on the actuator, otherwise the actuator may not unlock properly.
- Do not apply excessive shock to the interlock switch when opening or closing the door. A shock to the interlock switch exceeding $1,000\text{m/s}^2$ may cause damage to the interlock switch.
- If the operating atmosphere is contaminated, use a protective cover to prevent the entry of foreign objects into the interlock switch through the actuator entry slots. Entry of foreign objects into the interlock switch may affect the mechanism of the interlock switch and cause it to fail.
- Plug the unused actuator entry slot using the slot plug supplied with the interlock switch.
- Do not store the interlock switches in a dusty, humid, or organic-gas atmosphere, or where the switches are exposed to direct sunlight.
- Use proprietary actuators only. The interlock switch may be damaged if other actuators are used, .
- The actuator retention force is 3000N. Do not apply a load higher than the rated value. When a higher load is expected, provide an additional system consisting of another interlock switch without lock (such as the HS5D interlock switch) or a sensor to detect door opening and stop the machine.
- Regardless of the door, do not use the interlock switch as a door lock. Install a separate lock using a latch or other device.
- While the solenoid is energized, the interlock switch temperature rises approximately 40°C above the ambient temperature (to approximately 95°C while the ambient temperature is 55°C). To prevent burns, do not touch. If cables might come into contact with the interlock switch, use heat-resistant cables.
- The interlock switch solenoid has polarity. Be sure of the correct polarity when wiring.

Minimum Radius of Hinged Door

When using the interlock switch for a hinged door, refer to the minimum radius of doors as shown below. For doors with a small minimum radius, use actuators with adjustable angle (HS9Z-A3S).

Note: The following values apply when the actuator does not interfere with the interlock switch when opening and closing the door. Because deviation or dislocation of hinged door may occur in actual applications, make sure of the correct operation before installation.

When using HS9Z-A2S Actuator

- When the door hinge is on the extension line of the interlock switch surface:

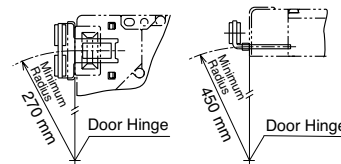

- When the door hinge is on the extension line of the actuator mounting surface:

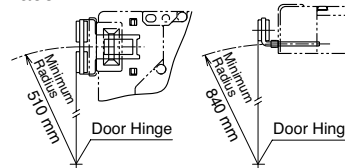

When using HS9Z-A3S Actuator

- When the door hinge is on the extension line of the interlock switch surface: 50mm
- When the door hinge is on the extension line of the actuator mounting surface: 80mm

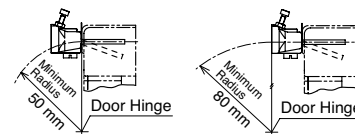

Actuator Angle Adjustment

- Using the angle adjustment screw, the actuator angle can be adjusted (refer to the dimensional drawing on page 4). Adjustable angle: 0 to 20°
- The larger the adjusted angle of the actuator, the smaller the applicable radius of the door opening. After installing the actuator, open the door. Then adjust the actuator so that its edge can be inserted properly into the actuator entry slot of the interlock switch.
- After adjusting the actuator angle, apply Loctite to the adjustment screw so that the screw will not move.

Instructions

Mounting Examples

Install the interlock switch and actuator referring to the figures below.

Application on Sliding Doors

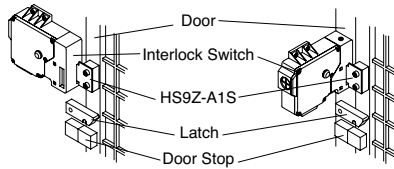

Application on Hinged Doors

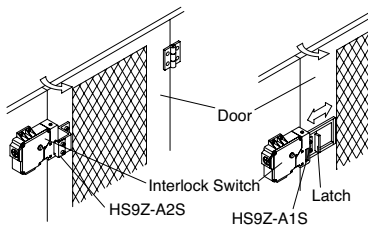

For Manual Unlocking

Spring lock type

The HS1L allows manual unlocking of the actuator to pre-check proper door movement before wiring or turning power on, as well as for emergency use such as in the case of a power failure.

Solenoid lock type

The solenoid lock type interlock switch normally does not need to be manually unlocked. However, only when the interlock switch would not release the actuator even though the solenoid is de-energized, the interlock switch can be unlocked manually. Unlock the interlock switch manually only when the solenoid is de-energized. Do not unlock the interlock switch manually when the solenoid is energized.

Using manual unlock key

- When locking or unlocking the interlock switch manually, turn the key fully using the manual unlock key supplied with the interlock switch.
- Using the interlock switch with the key not fully turned (less than 90°) may cause damage to the interlock switch or operation failure. When manually unlocked, the interlock switch will keep the main circuit disconnected and the door unlocked. Main circuit and lock monitor circuit remain open.
- Do not leave the manual unlock key attached to the interlock switch during operation. This is dangerous and does not satisfy safety standard requirements, because the interlock switch can always be unlocked while the machine is in operation.

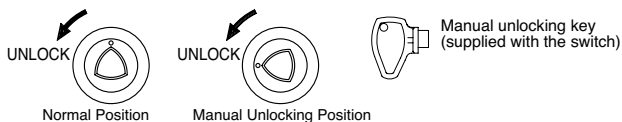

• Unlocking from the back of interlock switch

Insert the tip of a small screwdriver into the oblong hole on the back of the interlock switch, and tilt toward the center of the switch until the actuator is unlocked.

Note: Provide a hole on the mounting panel for unlocking from the back. When making a hole in the panel, take waterproof characteristics into consideration.

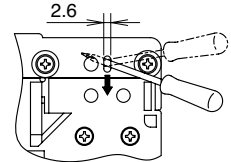

Safety Precautions

Before manually unlocking the interlock switch, make sure that the machine has come to a complete stop. Manual unlocking during operation may unlock the interlock switch before the machine stops, and the function of interlock switch with solenoid is lost.

On the solenoid lock type, manual unlocking is provided for the situation where the switch cannot be unlocked even though the solenoid has turned off. Do not attempt manual unlocking while the solenoid is energized.

Cover Opening and Closing Precautions

- When opening the cover before wiring, make sure to open only the cover shown the following figure. Removing unnecessary screws may cause a failure of the interlock switch.
- Use HS9Z-T1 key wrench for TORX screw when removing and installing the cover.
- Make sure that no foreign objects such as dust, water, or oil enter the interlock switch when wiring.

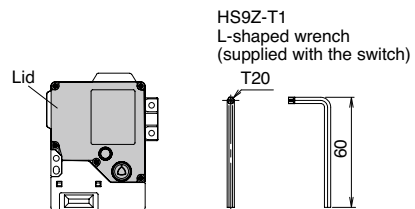

Applicable Crimping Terminal

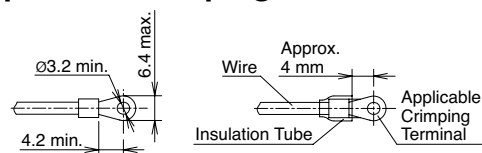

- Use an insulation tube on the crimping terminal.
- When using stranded wires, make sure that loose wires do not cause a short circuit. Also, do not solder the terminal to prevent loose wires.

Applicable Crimping Terminal	Applicable Wire
N0.5-3 / FN0.5 (JST)	0.2 to 0.5mm ²
N1.25-MS3 (JST)	0.25 to 1.65mm ²
V1.25-YS3A (JST)	0.25 to 1.65mm ²

Applicable Wire Size

- 0.5 to 1.5mm²

Applicable Cable Glands

Use IP67 cable glands.

HS1L Interlock Switches with Solenoid

Instructions

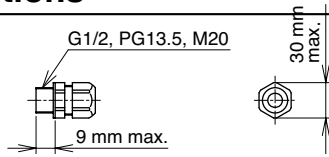

When Using Flexible Conduit (Example)

Flexible conduit example: VF-03 (Nihon Flex)

Conduit Port Size	Plastic Cable Gland	Metal Cable Gland
G1/2	-	RLC-103 (Nihon Flex)
PG13.5	-	RBC-103PG13.5 (Nihon Flex)
M20	-	RLC-103EC20 (Nihon Flex)

When Using Multi-core Cables (Example)

Flexible conduit example: VF-03 (Nihon Flex)

Conduit Port Size	Plastic Cable Gland	Metal Cable Gland
G1/2	SCS-10 (Seiwa Electric)	ALS-16 (Nihon Flex)
PG13.5	ST13.5 (K-MECS)	ABS-PG13.5 (Nihon Flex)
M20	ST-M20X1.5 (K-MECS) (Note)	ALS-EC20 (Nihon Flex)

• Different cable glands are used depending on the cable sheath external diameter. When purchasing a cable gland, confirm that the cable gland is applicable to the external diameter of the cable sheath.

Note: When using the ST-M20X1.5 cable gland, use with a gasket (GPM20, K-MECS).

Conduit Port Opening

- Make an opening for wiring by breaking one of the conduit port knockouts on the interlock switch housing using a screwdriver.
- Before opening the conduit port, remove the cable gland locking ring inside the interlock switch.
- When breaking the conduit port, take care not to damage the contact block or other parts inside the interlock switch.
- Cracks or burrs on the conduit entry may affect the water resistance of the interlock switch.
- If a different conduit port is used, cover the unused opening with an optional plug (part number: HS9Z-P1).

Recommended Tightening Torque

- HS1L interlock switch: 3.2 to 3.8 N·m (four M5 screws) (Note)
- Lid: 0.9 to 1.1 N·m (M4 screws)

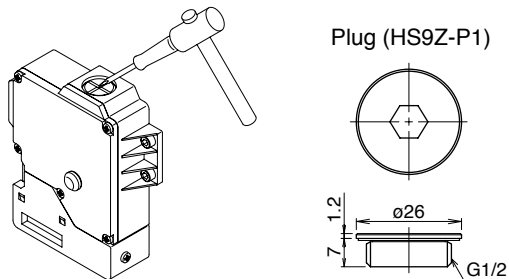

- Terminal: 0.6 to 0.8 N·m (M3 screws)
- Cable gland: 2.7 to 3.3 N·m
- Actuators
 HS9Z-A1S/A2S: 2.7 to 3.3 N·m (two M5 screws) (Note)
 HS9Z-A3S: 4.5 to 5.5 N·m (two M6 screws) (Note)

Note: The above recommended tightening torque of the mounting screws are the values when using hex socket head bolts. When other screws are used and tightened to a smaller torque, make sure that the screws do not become loose after mounting.

• Wire Length Inside the Interlock Switch

Screw Terminal No.	Through Conduit Port	
	①	②
11	95 ± 2	45 ± 2
21	85 ± 2	35 ± 2
22	60 ± 2	70 ± 2
31/33	75 ± 2	35 ± 2
32/34	50 ± 2	60 ± 2
42	65 ± 2	95 ± 2
51	45 ± 2	70 ± 2
52	55 ± 2	85 ± 2
61/63	35 ± 2	60 ± 2
62/64	45 ± 2	75 ± 2
A1	50 ± 2	45 ± 2
A2	60 ± 2	40 ± 2
X1	70 ± 2	35 ± 2
X2	80 ± 2	35 ± 2
Wire Stripping Length: L2 (mm)	7 ± 1	

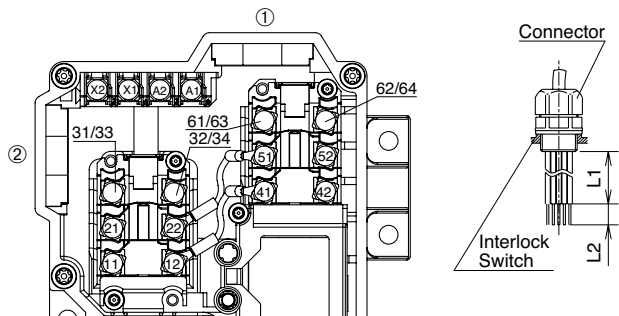

Note:

HS1L-R

Do not remove the wire between terminals 12-41, because these terminals are interconnected for safety circuit input. Use terminals 11-42 for safety circuit inputs. (GS-ET-19)

HS1L-DQ and HS1L-DT

Do not remove the wires between terminals 12-41 and 22-51, because these terminals are interconnected for safety circuit inputs. Use terminals 11-42 and 21-52 for safety circuit inputs. (GS-ET-19)

Specifications and other descriptions in this catalog are subject to change without notice.